

ALPHA PRESS



THE FASTEST, MOST RELIABLE PRESS TOOLS
EFFICIENCY MAX
SPEED UP 20%

3~4.5s

Per Cycle Time

30000

SERVICE INTERVAL



ED-1550

BATTERY POWERED PRESS TOOL

12-108mm [1/2"-4"] for PEX pipe

12-54mm [1/2"-2"] for copper & stainless steel pipe

THE RIGHT TOOL FOR YOUR NEED.

The ED-1550 is the newest addition to the press tool offered by ZUPPER, it gives another option for a fast and reliable way to join copper, stainless steel and PEX. The tool comes standard with two 18V, 3.0Ah Li-ion batteries and one charger, motor drives, Micro-computer control system, OLED screen and double valve hydraulic system, it can achieve over 300 cycles per charge.



SPECIFICATIONS

Capacity: 12-54mm [1/2"-2"] for copper & stainless steel	Battery: 18V Li-ion 3.0Ah
12-108mm [1/2"-4"] for PEX	Battery Charger: AC 100-240V
Output: 32KN	Charging Time: Approx. 1hour
Stroke: 40mm	Service Interval: 3000Cycles
Cycle Time: Approx. 3-4.5seconds	Weight: Approx.3.8kgs (tool with battery)
350° Swelling barrel	Approx.6.0kgs(tool with battery and jaw)
Oil capacity: 115ml	Tool Size: 388x322x84mm

ED-1550 Battery Press Tool Kit

MODEL NO.	DESCRIPTION	Weight(kgs)
ED-1550	ED-1550 Battery Press Tool Kit without jaws	9.15
	Battery, 18V, 3.0Ah Li-Ion	0.60
ACCESSORIES	Charger	0.70
	Plastic case	4.10

Kit includes: ED-1550 Press Tool, Two 3.0Ah Batteries, One Charger and Carrying Case.

ALPHA PRESS

POWERFUL, RELIABLE AND SIMPLY PRACTICAL
EFFICIENCY MAX
SPEED UP 20%

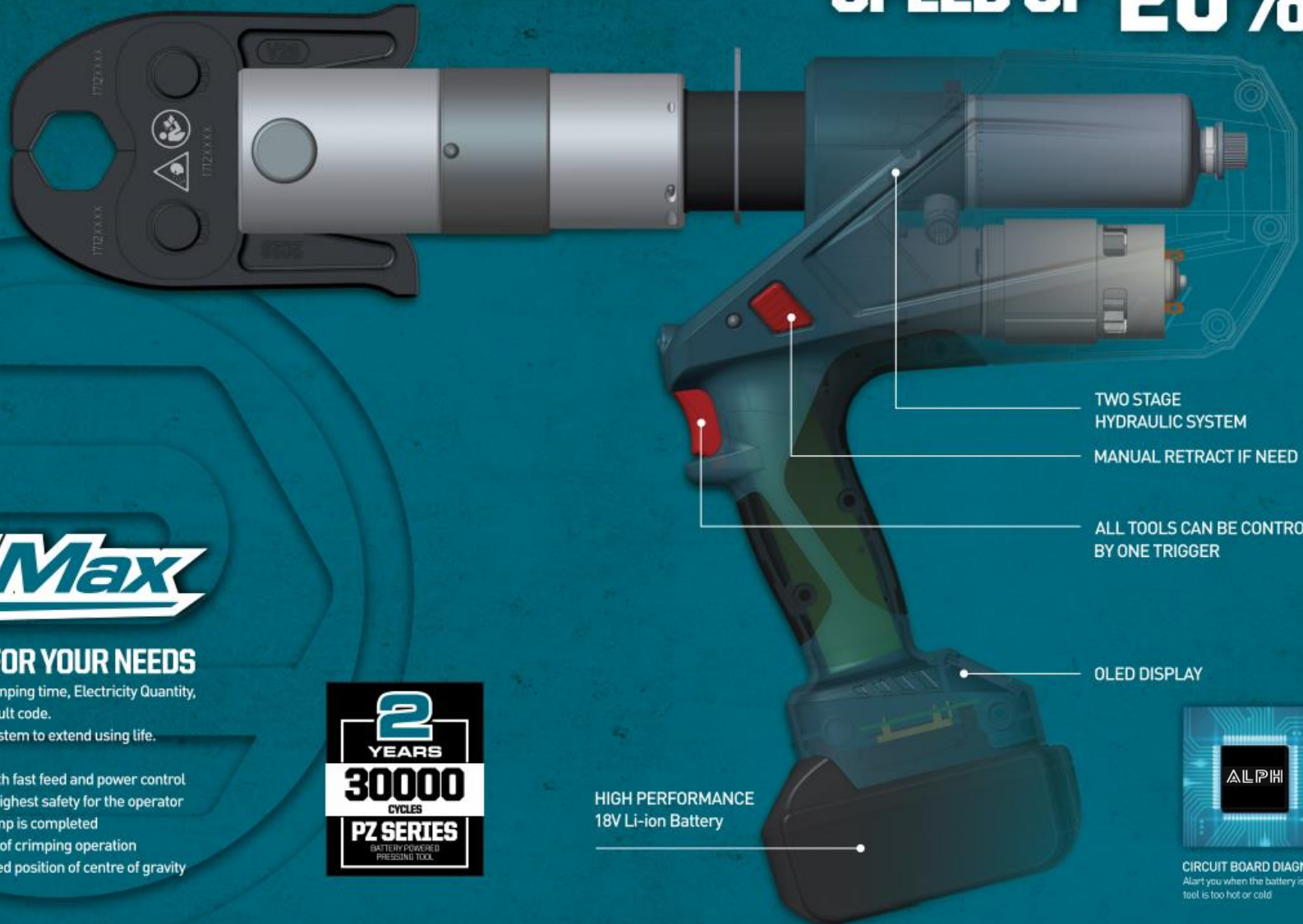

TWO STAGE
HYDRAULIC SYSTEM
MANUAL RETRACT IF NEEDED

ALL TOOLS CAN BE CONTROLLED
BY ONE TRIGGER

OLED DISPLAY

HIGH PERFORMANCE
18V Li-ion Battery



CIRCUIT BOARD DIAGNOSTICS
Alert you when the battery is low or the
tool is too hot or cold

EFFMax

THE RIGHT TOOL FOR YOUR NEEDS

- OLED Data Display to show crimping time, Electricity Quantity, maintenance reminding and fault code.
- Air Cooling Heat dissipation System to extend using life.
- Crimping head rotates 350°
- Two stage hydraulic system with fast feed and power control
- Quick motor stop guarantees highest safety for the operator
- Automatic retraction when crimp is completed
- Electronic control and monitor of crimping operation
- Ergonomic design and optimized position of centre of gravity



ALPHA PRESS



STANDARD SERIES PRESS JAWS

The Standard Series Pressing Jaws Were Designed In Conjunction With The Fitting Manufacturer, Ensuring Compatibility.



Adaptor/Pressing Rings for copper & stainless pipe from 42-54mm



Universal Jaw with interchangeable die fit for PEX pipe, Economic design for any needs.

Standard Series Press Jaws & Press Rings

DESCRIPTION	JAW SIZE	Weight (KGS)
PEX & MULTI-LAYER PIPE	TH16	2.05
	TH20	2.00
	TH25	-
	TH26	2.05
	TH32	2.10
	TH40	-



Standard Series Press Jaws

DESCRIPTION	JAW SIZE	Weight (KGS)
FOR STAINLESS STEEL / COPPER PIPE	M12	2.00
	M15	2.00
	M18	1.95
	M22	2.00
	M28	2.00
	M35	2.05
	M42	1.35
	M54	1.60



DESCRIPTION	JAW SIZE	Weight (KGS)
FOR STAINLESS STEEL / COPPER PIPE	V12	2.02
	V15	1.95
	V18	2.10
	V22	2.05
	V28	2.00
	V35	2.05
	V42	1.40
	V54	1.63



DESCRIPTION	JAW SIZE	Weight (KGS)
PEX & MULTI-LAYER PIPE	U16	1.95
	U20	2.05
	U25	2.00
	U32	2.15
	U40	2.20
	U50	-
	U63	2.47

